

F2E 320B Multiplane fan

320×280×80mm



Metal Blades

Dimensions

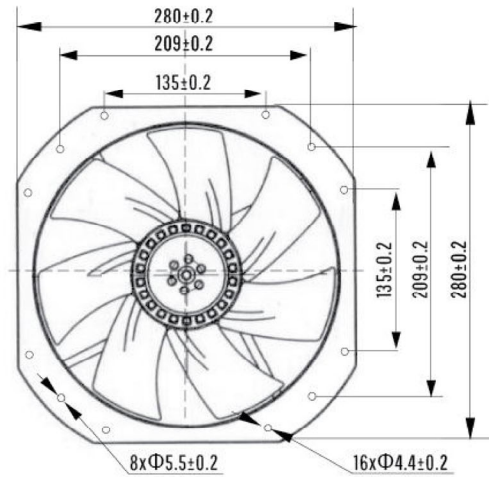
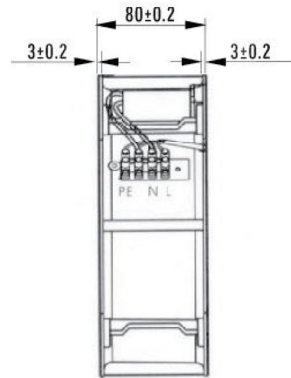

Motor Structure	Cage type structure motor.
Safety	Impedance Protected
Operation System	Dual high Precision ball bearings. (single sleeve bearing)
Allowable Ambient Temperature Range	(under unconcretionary condition) -20~+65°C(ball bearing) , -10~+45°C.(Sleeve bearing)
Insulation	B Class
Protection Grade	IP34

Type	F2E-320B-230	F2E-320B-115
Bearing	Ball	Ball
Rated operating voltage(V)	220-230	110-115
Rated frequency(Hz)	50/60	50/60
Rated current max.(A)	0.46-0.60	0.95-1.20
Rated Power(w)	140-100	140-100
Speed(RPM)	2500-2650	2480-2600
Wind volume(m ³ /h)	1800-1950	1800-1950
Noise dB(A)	68-70	68-70
Weight(g)	2900g	2900g