

# Industrial cabinet Air conditioner CTACG0526N

## ☆ Product features

- All metal shell, beautiful and durable
- The structure size is thin, which is convenient for the application of smaller space
- Coated heat exchanger, with large distance design, has higher anti-corrosion and dust-proof performance
- Levels of protection: IP54
- Normally open and normally closed alarm input, which greatly facilitates access to the monitoring in the cabinet
- High and low temperature and other alarm signal output
- RS485 interface, realize remote monitoring function through Modbus Protocol
- Nixie tube menu display, convenient for setting parameters and viewing alarm information
- R134a environment-friendly refrigerant, meeting ROHS requirements
- Condensate evaporation function option
- High reliability, 365 days / year, uninterrupted operation for 5-10 years

## ☆ Technical parameter

Boundary dimension (flange) (mm)	508*300*216
Weight (Kg)	20
Levels of protection	IP54 (Indoor) /IP34(Outdoor)
Surface treatment	Outdoor powderRAL7035
Refrigerating capacity (L35/L35) (W)	500
Refrigerating power consumption (W)	280
Operating temperature range (°C)	20~55
Air volume (m <sup>3</sup> /h)	180
Noise (dB(A))	60
Cryogen	R134a
Condensate management	Optional
Power supply system	AC 230V+10% 50/60Hz
Rated current (A)	1.3
Maximum current (A)	2.5
Locked rotor current (A)	5

## ☆ Dimension drawing

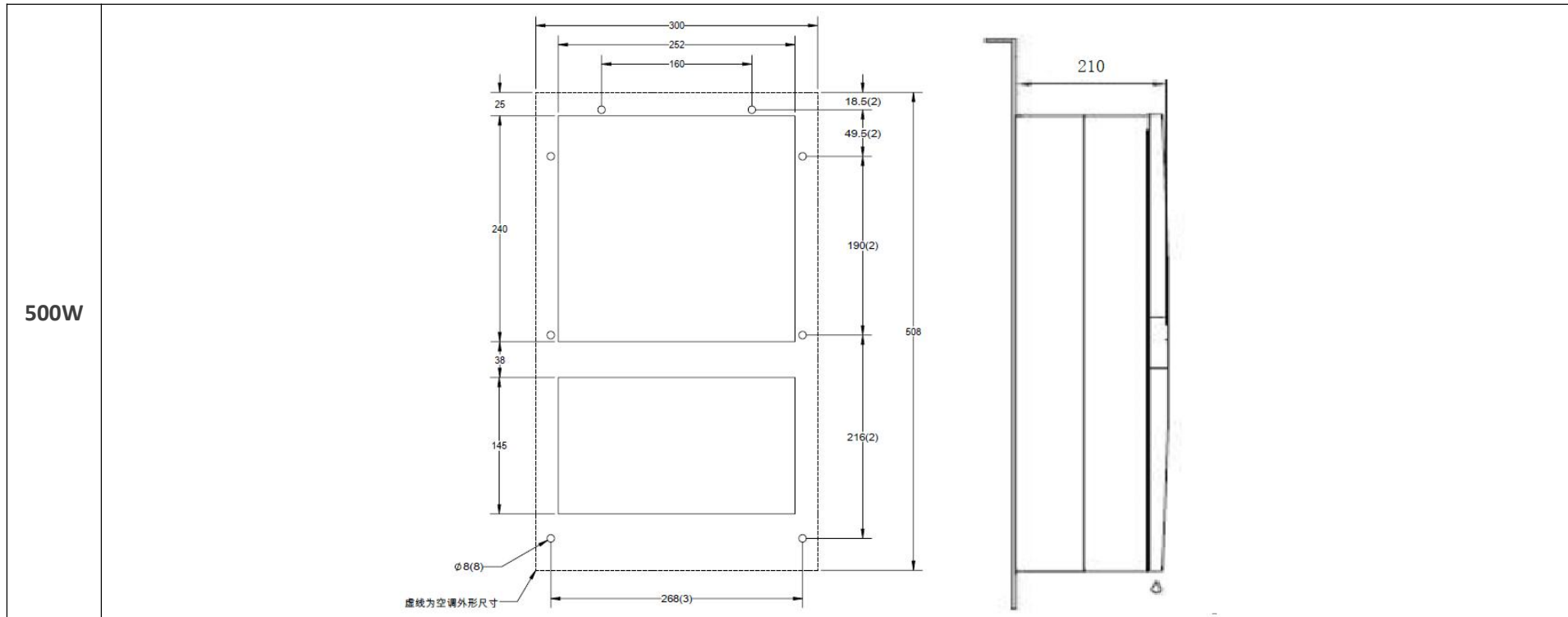

The dotted line is the appearance dimension of the air conditioner.

☆Electrical wiring diagram

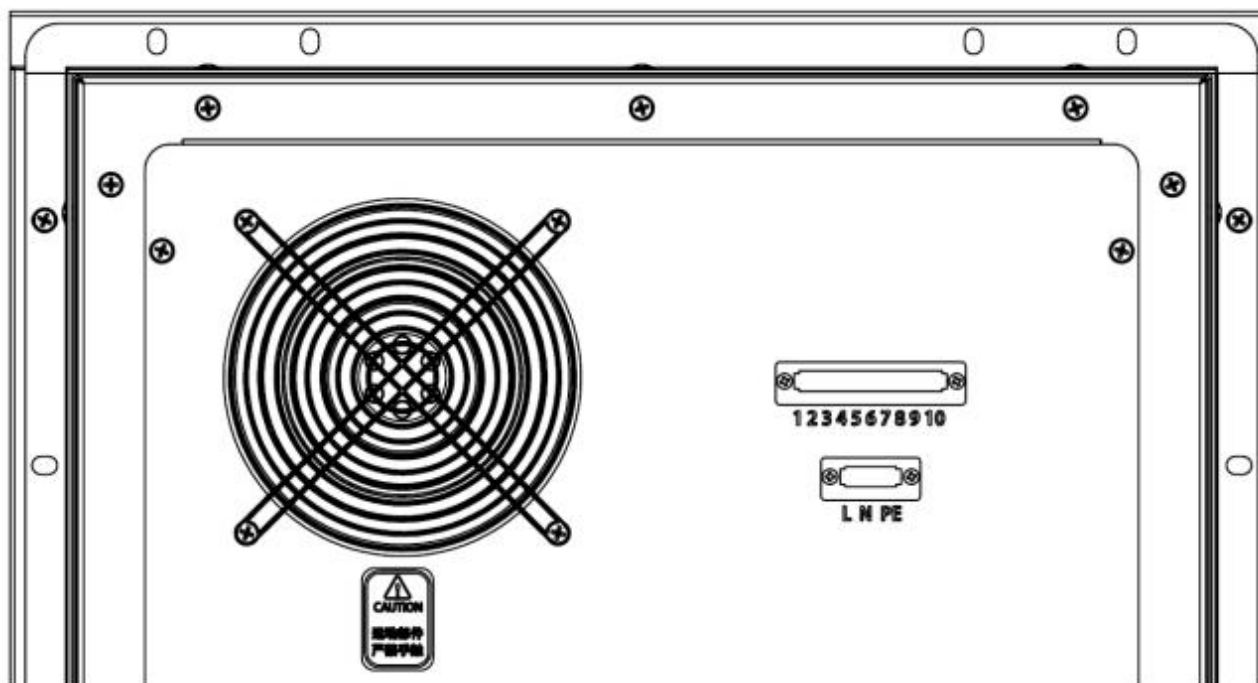

**Power line wiring**

- ❖ Maximum allowable wire diameter 2.5mm<sup>2</sup>
  - ❖ L- Power cord
  - ❖ N- Power zero line
  - ❖ PE- Power Earth

**Signal line wiring**

- ❖ 1-2 Alarm output - fault closed
- ❖ 2-3 Alarm output - fault on
  - ❖ 4-5 Alarm Inputs
- ❖ RS485 7-A / 8-B / 6-GND