

Electronic Timer - Series Micon® 175

- Multi-Function: 10 Different (Non-Signal & Signal based) Modes
- Wide Voltage range for both AC & DC
- Wide Time range: 0.1s - 100h
- LED Indications for Power and Relay status
- Independent settings for both ON Time & OFF Time
- Low Power Consumption





Ordering Information

Cat. No.	Description
1CMDT0	12 - 240 VAC/DC, Multi Function Timer (10 Modes), 1 C/O
1CMDTF	12 - 240 VAC/DC, Multi Function Timer (10 Modes), 2 C/O
1CQDT9	12 - 240 VAC/DC, Multi Function Timer (10 Modes), 1 C/O - 16A
1CVDT9	12 - 240 VAC/DC, Multi Function Timer (10 Modes & 10 Ranges), 1 C/O - 16A
1CJDT0	12 - 240 VAC/DC, Asymmetric Timer, 1 C/O

Electronic Timer - Series Micon® 175



Cat. No.	1CMDT0	1CMDTF	1CQDT9	1CJDT0
Parameters	Multi Function Timer			Asymmetric Timer
Timer Description				
Modes	1) Signal ON Delay 2) Cyclic ON/OFF 3) Cyclic OFF/ON 4) Signal OFF Delay 5) Signal OFF/ON 6) Accumulative Delay on Signal 7) Impulse ON/OFF 8) Leading Edge Impulse 9) Trailing Edge Impulse 10) Leading Edge Bi-stable			1) Asymmetric ON-OFF, 2) Asymmetric OFF-ON
Derived Modes	ON Delay, Interval			N A
Supply Voltage (ϕ)	12 - 240 VAC/DC			
Supply Variation	-15% to +10% (of ϕ)			
Frequency	50/60 Hz			
Power Consumption (Max.)	5 VA			
Timing Range	0.1s to 100h			
Reset Time	200 ms (Max)			
Setting Accuracy	± 5% of Full scale			
Repeat Accuracy	± 1%			
Output	Relay Output	1 C/O	2 C/O	1 C/O
	Contact Rating	8A @ 240 VAC / 5A @ 24 VDC (Resistive)		16A @ 240 VAC / 16A @ 24 VDC (Resistive)
	Electrical Life	5X10 ⁵		
	Mechanical Life	1X10 ⁶		
Utilization Category	AC - 15	Rated Voltage (Ue): 120/240 V, Rated Current (Ie): 3.0/1.5 A		
	DC - 13	Rated Voltage (Ue): 24/125/250 V, Rated Current (Ie): 2.0/0.22/0.1 A		
Operating Temperature	-10°C to +60°C			
Storage Temperature	-15°C to +70°C			
LED Indication	Green LED → Power ON Yellow LED → Relay ON		Green LED → Power ON Amber LED → Relay ON	
Enclosure	Flame Retardant UL94-V0			
Dimension (W x H x D) (in mm)	18 X 60 X 85			
Weight (unpacked)	72 g			
Mounting	DIN Rail			
Certification	  			
Degree of Protection	IP 20 for Terminals, IP 30 for Enclosure, IP 40 for Front side			

EMI / EMC

Harmonic Current Emissions	IEC 61000-3-2
ESD	IEC 61000-4-2
Radiated Susceptibility	IEC 61000-4-3
Electrical Fast Transients	IEC 61000-4-4
Surges	IEC 61000-4-5
Conducted Susceptibility	IEC 61000-4-6
Voltage Dips & Interruptions (AC)	IEC 61000-4-11
Voltage Dips & Interruptions (DC)	IEC 61000-4-29
Conducted Emission	CISPR 14-1
Radiated Emission	CISPR 14-1

Environmental

Cold Heat	IEC 60068-2-1
Dry Heat	IEC 60068-2-2
Vibration	IEC 60068-2-6

Electronic Timer - Series Micon® 175



FUNCTIONAL DIAGRAMS FOR 1CMDT0

⏏: Supply Voltage, S: Input Signal, R: Relay Output
 T: Preset Time, TON: Preset ON Time, TOFF: Preset OFF Time

SIGNAL ON DELAY [stn]

On application of input signal, the preset delay time period starts. On completion of the preset time, the output is switched ON and remains ON till the input signal is present.

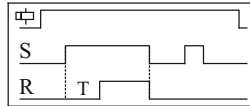

ACCUMULATIVE DELAY On SIGNAL [san]

On application of supply voltage, the preset delay time period starts. If input signal is applied during this period, the preset time stops and resumes only when the input signal is removed. On completion of the preset time, the output is switched ON.

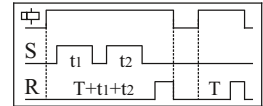

CYCLIC ON/OFF [cnf]

On application of supply voltage, the output is initially switched ON for the preset time duration (T) after which it is switched OFF for the same time duration (T). This cycle continues till the power supply is present.



IMPULSE ON/OFF [inf]

On application or removal of input signal to the timer, the output is immediately switched ON for the preset time duration (T). If the state of the input signal is changed during the preset time, the output does not change state only the time is reset.

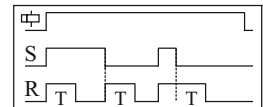

CYCLIC OFF/ON [cfn]

On application of supply voltage, the output is initially switched OFF for the preset time duration (T) after which it is switched ON for the same time duration (T). This cycle continues till the power supply is present.



LEADING EDGE IMPULSE [il]

When input signal is applied to the timer the output is immediately switched ON. The output remains ON for the preset time duration (T) after which it is switched OFF. If the input signal is removed during the preset time, the output is immediately switched OFF.

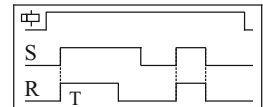

SIGNAL OFF DELAY [sf]

On application of input signal to the timer, the output is immediately switched ON. When the input signal is switched OFF, the preset time delay period starts. On completion of the time period the output is switched OFF.

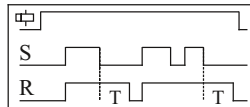

TRAILING EDGE IMPULSE [it]

When the input signal to the timer is removed, the output is immediately switched ON for the preset time duration (T) after which it is switched OFF. If the input signal is applied during the preset time, the output is immediately switched OFF.

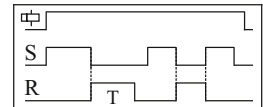

SIGNAL OFF/ON [sfn]

On application of input signal to the timer, the preset delay time period (T) starts. On completion of the time preset time, the output is switched ON. When the input signal is switched OFF, again the preset time delay period (T) starts. On completion of the time period the output is switched OFF.

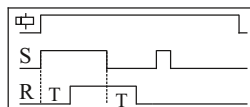

LEADING EDGE BISTABLE [sbi]

On application of input signal to the timer, the output is switched ON and remains ON even after the input signal is removed. On subsequent application of input signal, the output keeps on changing its state.

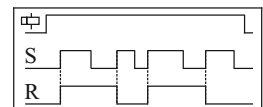

DERIVED MODES

Select 'Signal ON Delay' Mode and short the connection between A1-B1 before power ON OR Select 'Accumulative Delay ON Signal' Mode and keep the connection between A1- B1 open.

ON DELAY

When supply power is applied to the timer, the preset delay time period starts. On completion of the preset time, the output is switched ON and remains ON till the input supply is present.

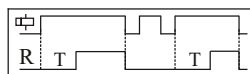

Select mode, "Leading Edge Impulse" and short the connection between A1 & B1.

INTERVAL

When supply power is applied to the timer, the output is instantly switched ON. On completion of the preset time, the output is switched OFF.

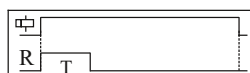

FUNCTIONAL DIAGRAMS FOR 1CJDT0

MODE A

ASYMMETRIC OFF-ON

On application of supply voltage, the output is initially switched OFF for the preset 'OFF' time duration (T) after which it is switched ON for the preset 'ON' time duration (T). This cycle repeats and continues till the supply is present. The ON time & OFF time are set independently.

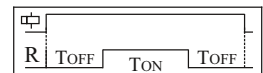

MODE B

ASYMMETRIC ON-OFF

On application of supply voltage, the output is initially switched ON for the preset 'ON' time duration (T) after which it is switched OFF for the preset 'OFF' time duration (T). This cycle repeats and continues till the supply is present. The ON time & OFF time are set independently.



Note: Refer page number 28 for Connection Diagram

Electronic Timer - Series Micon® 175

MOUNTING DIMENSIONS (mm)

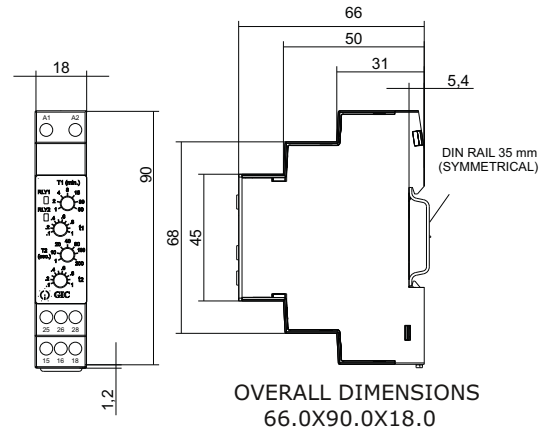
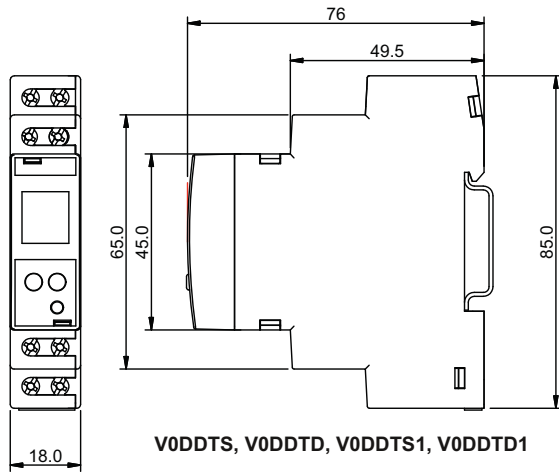

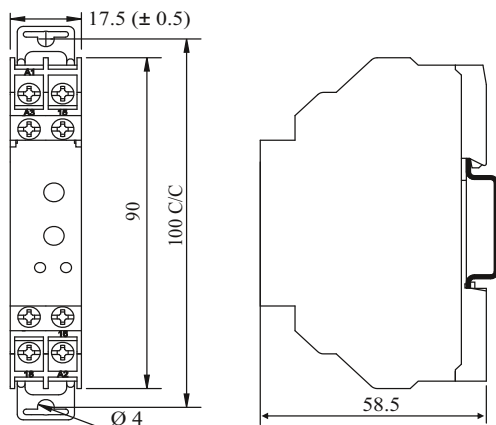

All Dimensions are in mm
**1CMDT0, 1CQDT9, 1CJDT0, 1CMDTF, 1CZDTF STAIRCASE TIMER
 11WDT, 12WDT**



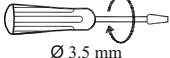

**110DT4, 120DT4, 150DT4, 11SDT0, 12SDT0
 11ODT8, 12ODT8, 11BDT4, 12BDT4, 15BDT4**

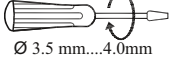

TERMINAL TORQUE & CAPACITY

 Ø 3.5 mm	0.54 N.m (6 Lb.in)
	1 x 2.5 mm ² Solid/Stranded Wire
AWG	1 x 24 to 12

V0DDTS, V0DDTD, V0DDTS1, V0DDTD1, STAIRCASE TIMER

 Ø 3.5 mm...4.0mm	0.6 N.m (5.3 Lb.in)
	1 x 4.0 mm ² Solid/Stranded Wire
AWG	1 x 20 to 10

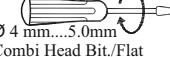
1CMDT0, 1CQDT9, 1CJDT0

 Ø 4 mm...5.0mm Combi Head Bit/Flat	0.5 N.m (4.4 Lb.in) to 0.7 N.m (6.2 Lb.in)
	2 x 2.5 mm ² Solid/Stranded Wire
AWG	20 to 12

**110DT4, 120DT4, 150DT4, 11SDT0, 12SDT0
 11ODT8, 12ODT8, 11BDT4, 12BDT4, 15BDT4**

Electronic Timer - Series Micon® 175

CONNECTION DIAGRAM

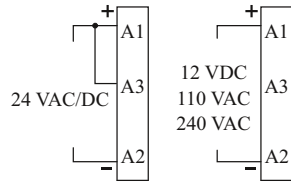

**110DT4, 120DT4, 150DT4,
11SDT0, 12SDT0, 11ODT8,
12ODT8, 11BDT4, 12BDT4, 15BDT4**

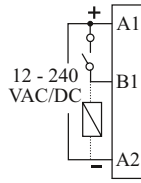

**1CMDT0,
1CQDT9,
1CJDT0**

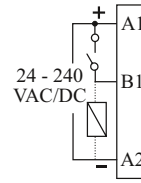

**V0DDTS, V0DDTD,
V0DDTS1, V0DDTD1**

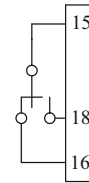

**110DT4, 120DT4, 150DT4,
11SDT0, 12SDT0, 11ODT8,
12ODT8, 11BDT4, 12BDT4,
15BDT4, 1CMDT0, 1CJDT0,
1CQDT9, V0DDTS, V0DDTS1**

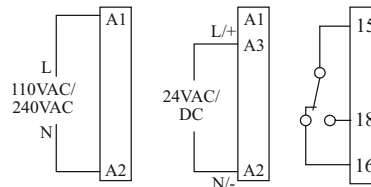
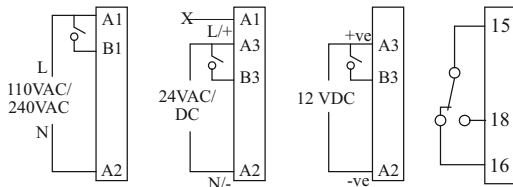

11WDT4, 12WDT4

⚠ Do not apply more than 27VAC/DC to A3 terminal of 11WDT4 & 12WDT4.

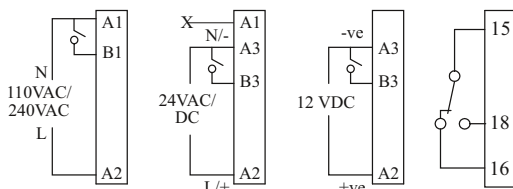

11RDT4, 12RDT4, 15DDT4

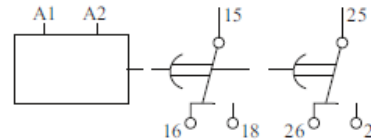

1CMDTF

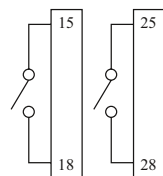

**V0DDTD, V0DDTD1,
STAIRCASE TIMER**

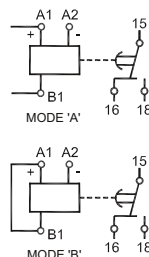

1CJDT0

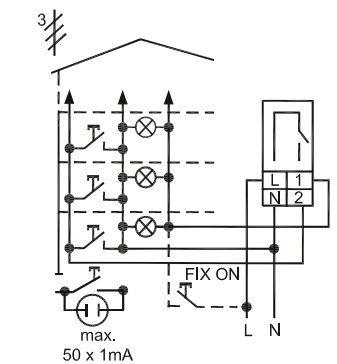

3 Wire rising main without Loft illumination

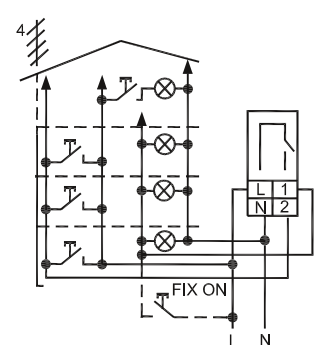

4 Wire rising main without connection for Loft illumination

STAIRCASE TIMER